

MONTEER 6500S V2.0 USER MANUAL

ACCESSORY/STRUCTURE

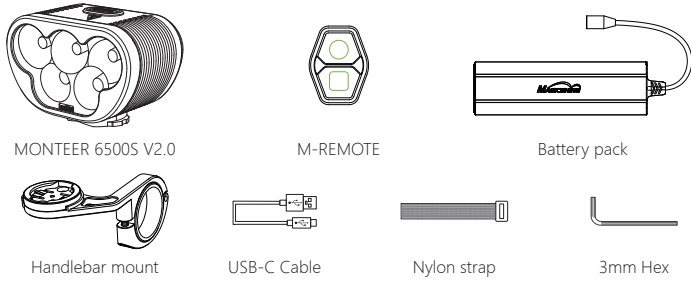

HOW TO INSTALL

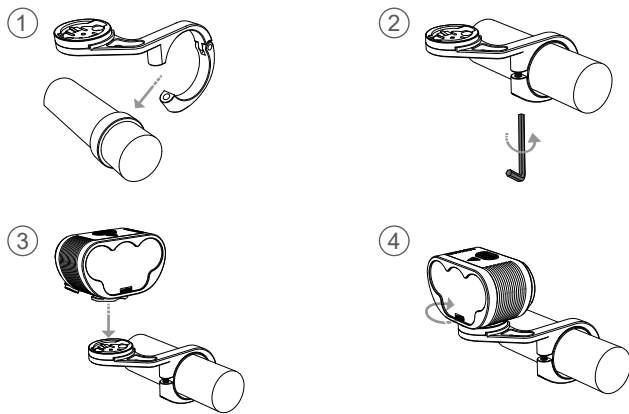

HOW TO INSTALL BATTERY PACK

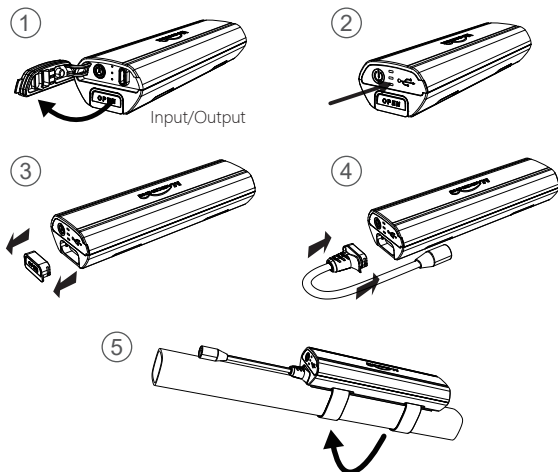

BATTERY FEATURES

High capacity battery pack with 4*21700 Li-ion battery cells 7.2V 10 Ah.
 Multiple circuit protections for safety use.
 High quality fireproof PC material for shell.
 Type-C charging & discharging integrated interface for 10w/18w fast output.

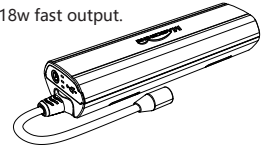

BATTERY INDICATOR

When the light is off, press the power button to display the remaining power.

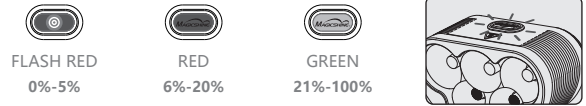

HOW TO RECHARGE



SWITCHING THE LIGHTING MODE

Long press power button to turn on/off
 When you turn the light on, it lights up in the last lighting mode you used.
 (Mode memory function)

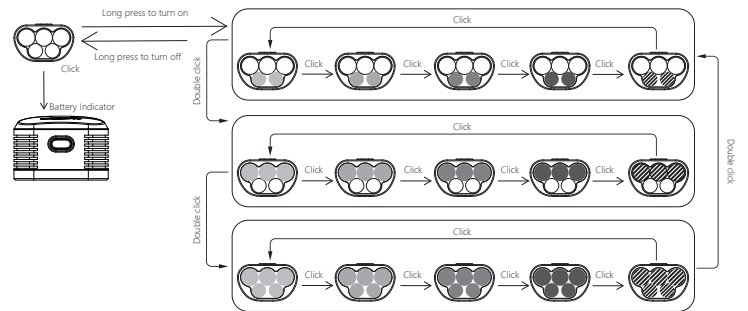

LUMENS/RUN TIME

MODE	BRIGHTNESS	ECO	LOW	MID	HIGH	FLASH
	LUMENS	300	700	1300	2600	0-650
	h:min	40:00	20:30	11:00	05:30	18:00
	LUMENS	500	1100	2200	4000	0-1100
	h:min	27:30	13:30	07:00	03:30	14:00
	LUMENS	900	1900	3600	6500	0-2000
	h:min	16:00	07:35	04:00	02:00	08:00

HOW TO PAIR

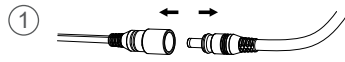

Disconnect the lighthouse from the battery



Press the two buttons at the same time until the indicator light flashes

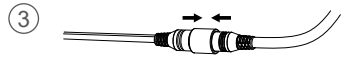

Reconnect the lighthouse to the battery

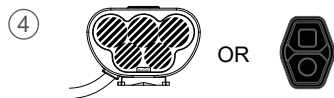

Pairing is successful: the lighthouse flashes once or the indicator light stops flashing

*The M-REMOTE can only be paired with one device. To pair a new device, please repeat the operation steps above.

HOW TO USE THE M-REMOTE

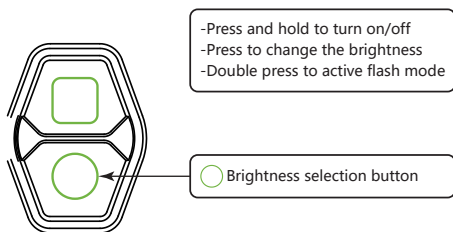
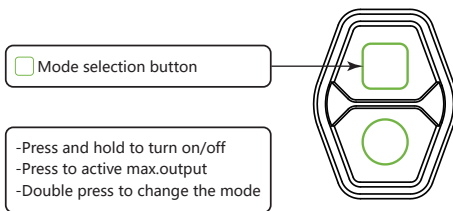

OPTIONAL PARTS



Helmet mount

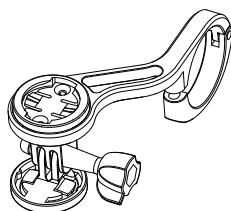

TTA front mount

*Adaptable accessories (sold separately)

⚠ WARNING

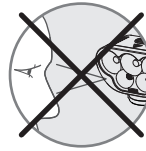

EN WARRANTY

The Magicshine lighting system is warranted for 24 months from the date of purchase.

If you register the lighting system on the Magicshine website you will receive a bonus 6 month warranty.

Battery packs and AC adapters have a 6 month warranty, however, there is no bonus warranty available.

The warranty is limited to defects in material and workmanship on the lighting system itself, the battery pack and the AC adapter.

The warranty is only valid if the affected parts have not been tampered with and there is no intentional damage. Please keep your proof of purchase in a safe place. Proof of purchase must be presented in the event of any claim. Please contact the specialist retailer from whom you purchased the device for complaint or warranty claim.

Alternatively, you can send your complaint or claim directly to Magicshine at

Tel: (+86) 755-295 536 69

Fax: (+86)755-275 897 77

E-mail: support@magicshine.com (order from Magicshine.com online store)

service@magicshine.com (order from other sales channels)

In the event of a justified warranty claim and delivery of a replacement device, you will only be entitled to a model available when replacing. The manufacturer retains the right to make technical modifications.

ANSI FL 1 STANDARD

LIGHT OUTPUT	BEAM DISTANCE	PEAK BEAM INTENSITY	IMPACT RESISTANCE	WATER RESISTANT
6500 LUMENS	280m	20000cd	1m	

