

FB8102 – KFB8102

Traversino - Fairing upper bracket - Support gps pour carenage - Barra
Halterung zur montage am windschild - Suporte
PEUGEOT XP400 GT / XP400 ALLURE (2023)

N°	Descrizione/Description	Caratteristiche/Features	Codice/Code	Quantità/Quantity
1	Supporto - Support - Support Halterung - Soporte - Apoio	-	GL5639V	1
2	Supporto superiore - Support higher - Support supérieur Halterung höher - Soporte superior - Apoio superior	-	V974N	1
3	Vite - Screw - Vis - Schraube Tornillo - Parafuso	TBEIFF M6x16	616TBEIFF	2
4	Rondella spaccata - Split washer - Scheibe - Rondelle fendue Arandela seccionada - Arruela quebrada	Foro Ø6mm	Z1063	2
5	Componenti Originali - Original Parts Parties Originales - Original Bauteile Componentes Originales - Componentes Originais	-	-	-

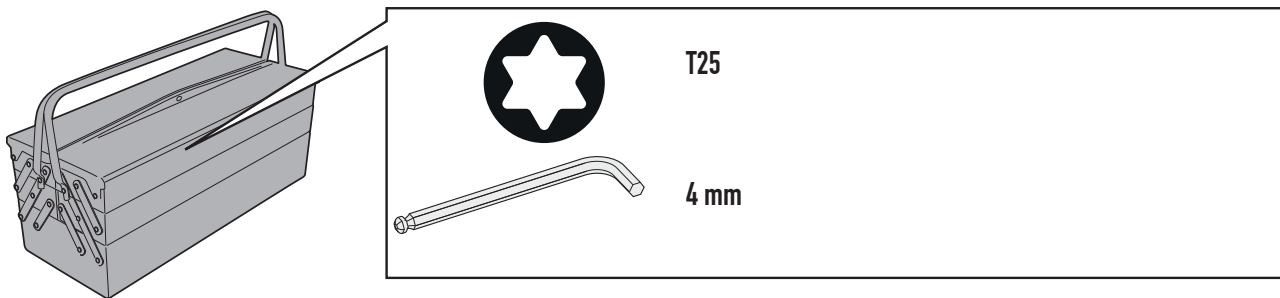
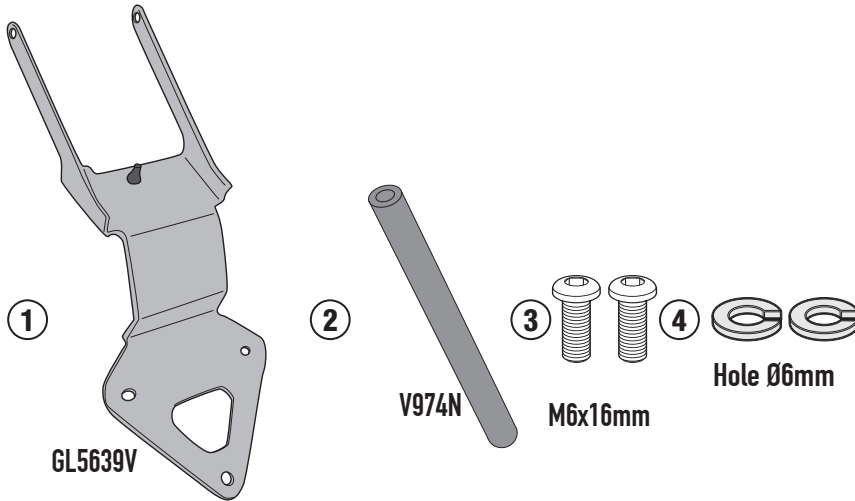

IT_ Nel caso in cui sulle viti originali sia presente del frenafilletti, ripristinarlo durante il montaggio dell'accessorio.

EN_ If there is threadlocker on the original screws, use threadlocker when mounting the accessory.

DE_ Falls sich auf den Originalschrauben Schraubensicherungs-klebstoff befand, sollte dieser auch bei der Montage des Zubehörs wieder aufgetragen werden

FR_ Si du frein filet est présent sur les vis d'origine, l'appliquer également lors du montage de l'accessoire

ES_ En caso de que el fijador de roscas se encuentre presente en los tornillos originales, colocarlo nuevamente en el montaje del accesorio

PT_ Se houver trava rosca nos parafusos originais, inserir novamente durante a montagem do acessório

FB8102 – KFB8102

Traversino - Fairing upper bracket - Support gps pour carenage - Barra
 Halterung zur montage am windschild - Suporte
PEUGEOT XP400 GT / XP400 ALLURE (2023)

