

**Important:** If you are not a trained motorcycle mechanic stop now. Ask a local motorcycle shop to do the work for you!

## Please take extra care!

You have to mount the crash pads one side after the other!

At all times you have to prevent that the engine mounting bolts are loose at the same moment!

For tightening torque of the engine bolts look at the work shop manual!

## Fitting on the right side

(view from rear)

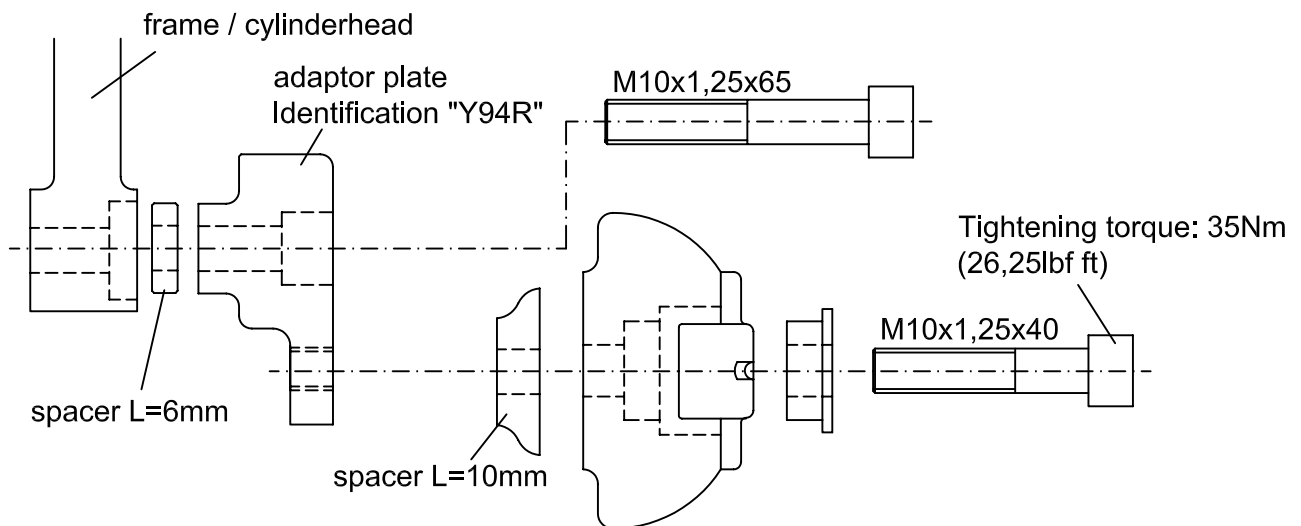

## Fitting on the left side

(view from rear)

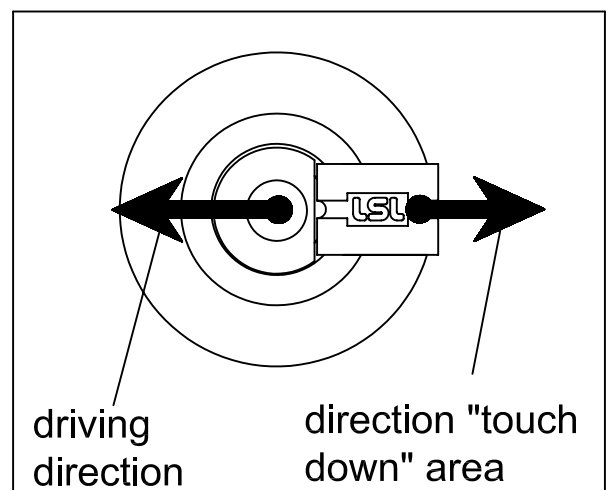
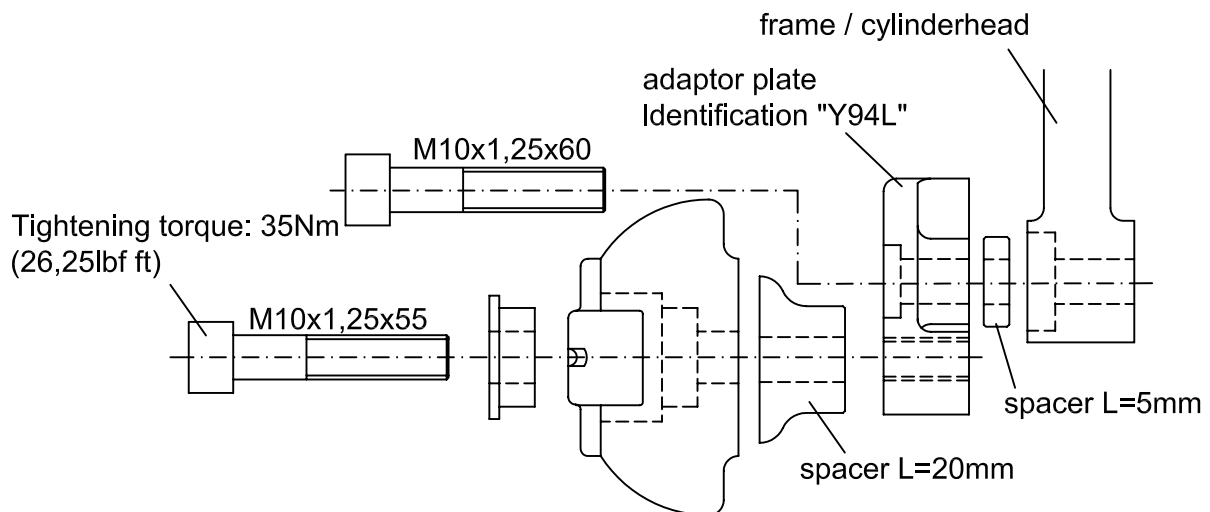

LSL-Motorradtechnik GmbH • D-47809 Krefeld

[www.lsl-motorradtechnik.de](http://www.lsl-motorradtechnik.de)

Stand: 05/2006