

**Wichtig:** Wenn Sie kein ausgebildeter Mechaniker sind, wenden Sie sich an eine Fachwerkstatt!  
Die Crash Pads werden am Rahmen, zwischen die beiden Zylindern montiert. Den orig. Motorhaltebolzen entfernen und beiliegenden Bolzen 485mm und die Distanzbuchsen wie gezeigt montieren. Bitte darauf achten, daß die beiden Muttern M12 gleichmäßig auf den Motorhaltebolzen geschraubt werden.  
**Anzugsdrehmoment: 60Nm!**

## Anbau (Ansicht von oben)

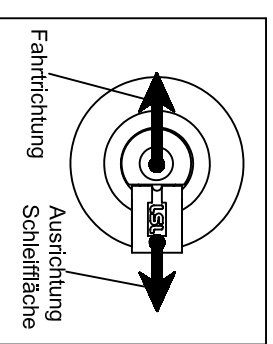
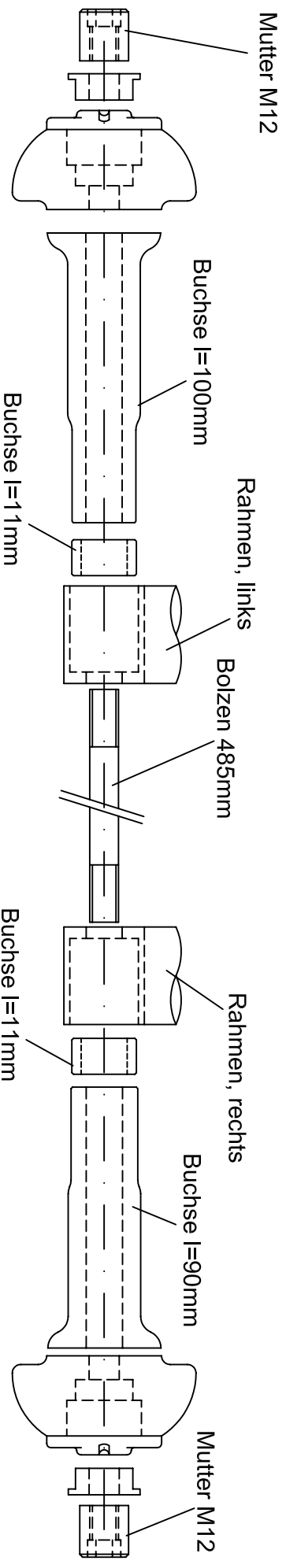

**Important:** If you are not a trained motorcycle mechanic, stop now! Ask a local motorcycle shop to do the work for you!

The Crash Pads are at the frame, between the cylinders. Demount the original engine bolt and use the attached bolt 485mm with spacers as shown on the drawing. Assure that the nuts are screwed even on the bolt at both sides.

**Tightening torque: 44.44 lbf ft / 60Nm!**

## Mounting

(view from top)

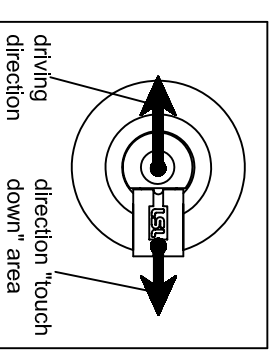
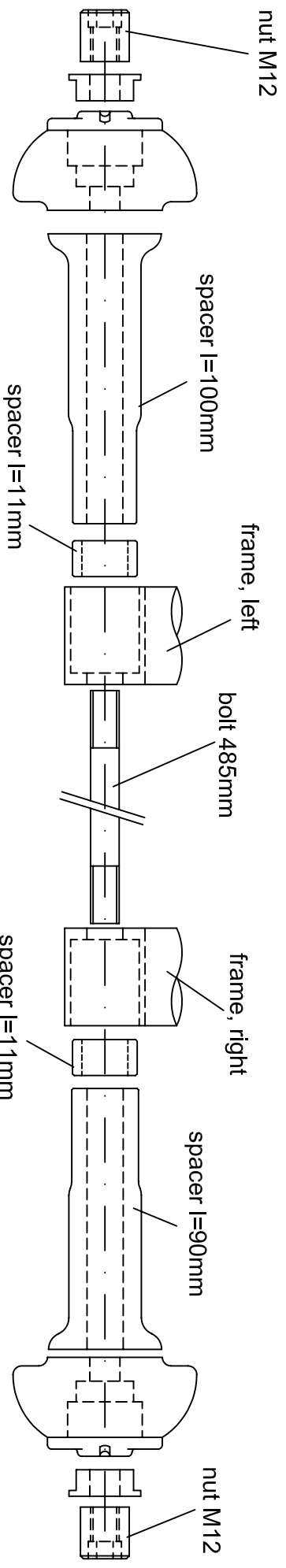

LSL-Motorradtechnik GmbH • D-47809 Krefeld

[www.lsl.eu](http://www.lsl.eu)

Rev. 00 15/09/2009

## **Instructions de montage pour Crash Pads pour Ducati Streetfighter**

**N° article : 550D037**

Les Crash Pads se montent entre les deux cylindres. Remplacer l'axe de fixation moteur et fixer les Crash Pads avec les entretoises comme indiqué ci-dessous. Serrer en alternance, de manière régulière, les deux écrous M12 à un couple de 60Nm.

### **Montage** (Vue de dessus)

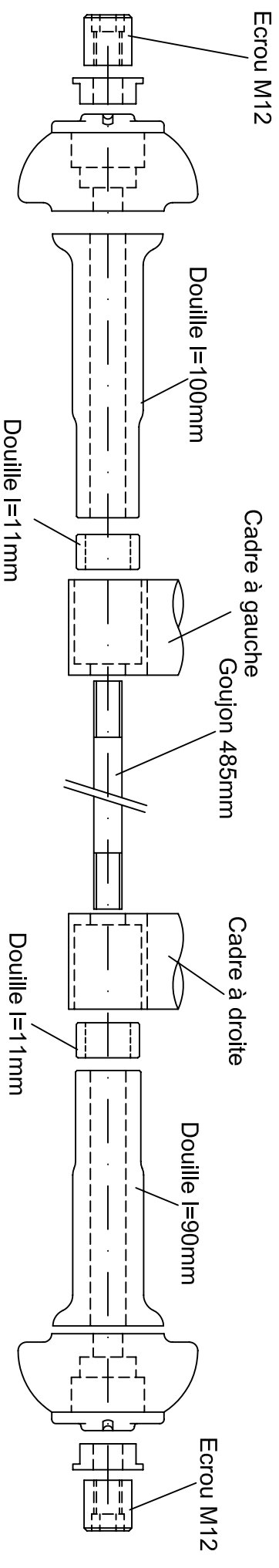

LSL-Motorradtechnik GmbH • D-47809 Krefeld

[www.lsl.eu](http://www.lsl.eu)

Rev. 00 17/08/2009

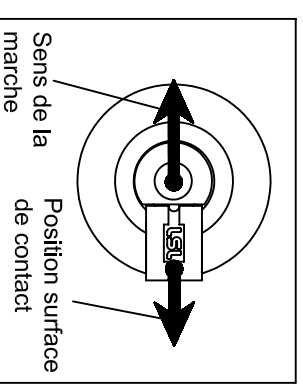



LSI-Motorradtechnik GmbH • D-47809 Krefeld

[www.lsi.eu](http://www.lsi.eu)